

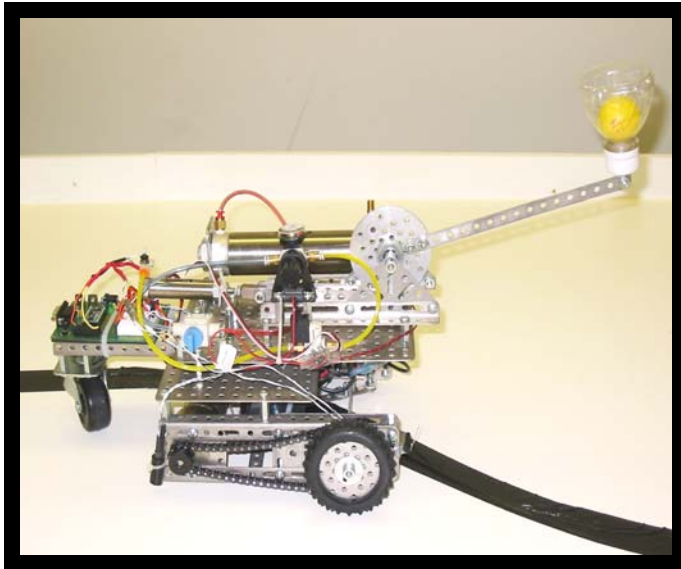

## Build an Autonomous Game Playing Robot

**Note:** Only students who have successfully completed these three GEARS-IDS™ projects should attempt this project: **Mobile Chassis, Pneumatic Test Stand, Configure an RC Control System.**



### Autonomous Robots

Use The **GEARS-IDS™** Invention and Design System and a **Parallax BASIC Stamp™** ([www.parallax.com](http://www.parallax.com)) micro controller to build an autonomous machine capable of following a line, finding a wall, and shooting a ping pong ball into a basket up to 10 feet away!

### Before You Start This Project

The robot used in this tutorial was built by integrating these three GEARS modules:

- **Mobile Chassis**
- **Pneumatic Test Stand.**
- **RC Control System**
- **Parallax Basic Stamp**

Detailed descriptions and illustrated directions for building these modules are available in the **PROJECTS** section of the GEARS website. ([www.gearseds.com](http://www.gearseds.com)) We recommend that you complete these projects **BEFORE** you attempt the autonomous game playing robot project.

### Build an Autonomous Game Playing Robot and Learn these Science and Engineering Skills

#### Mechanical Principles

- Gear Ratios
- Force and Pressure
- Structures and Fasteners
- Integrate Components and Subassemblies

#### Science and Engineering Principles

- Embedded Control
- Sensors
- Programming
- Basic Electronics
- Basic Physics

#### Design Principles

- Concerns and issues involved in integrating components, modules and subassemblies
- Fits and interferences
- Trouble Shooting

#### Personal and Interpersonal Skills

- Acquires and Evaluates Information
- Allocates and Organizes Time and Materials
- Solves

**NOTE:** This project uses the **Parallax BASIC Stamp™** micro controller. Parallax offers downloadable tutorials that make learning to use the BASIC Stamp easy and enjoyable.

Please take the time to become familiar with the **BASIC Stamp™** by using the Parallax educational resources. Parallax educational downloads are available on the Parallax website. ([www.parallax.com](http://www.parallax.com))

BASIC™ Stamp Components can be purchased from GEARS Educational systems, or directly from Parallax Inc.

# First Things First

The Autonomous Game Playing Robot is one of the more challenging activities in the **GEARS-IDS™** project series. Successful completion of this project requires the successful completion of the GEARS-IDS projects listed below, as well as a working familiarity with basic electronic components, wiring and use of the Parallax BASIC Stamp and prototyping Board of Education.

## Follow This Procedure to Prepare the Robot

- 1.) Build the Drive Train and Mobile Chassis
- 2.) Build the Pneumatic Test Stand.
- 3.) Integrate these two components
- 4.) Configure an RC Controller

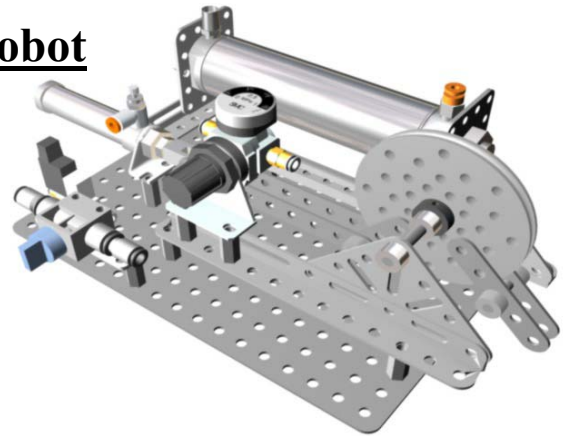

### 2.) Build the Pneumatic Test Stand

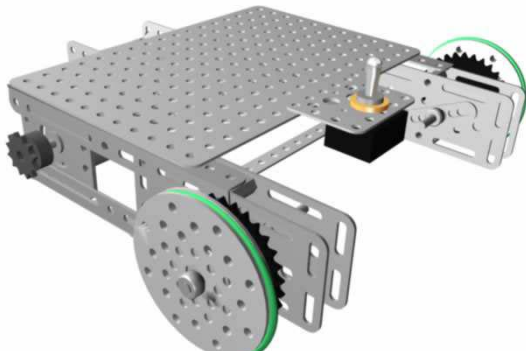

### 1.) Build the Drive Train and Mobile Chassis

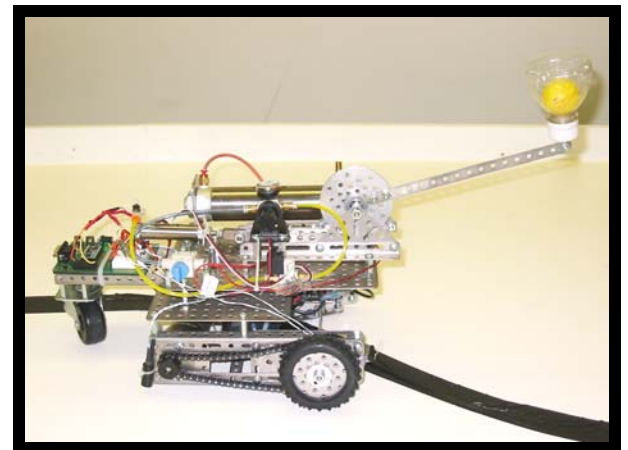

### 3.) Integrate the Drive Train and Pneumatic Test Stand Modules

**1.) Assemble the Drive Train and Mobile Chassis.** Download the illustrated guide to constructing the drive train and chassis from the projects section of the GEARS Educational Systems website ([www.gearseds.com](http://www.gearseds.com)). This module can be assembled in 1-2 hours by a team of 2-3 people. Each team member can build 1 or more of the subassemblies from which the drive train and chassis are constructed. Allow additional time for testing and debugging.

**2.) Assemble the Pneumatic Test Stand** Download the illustrated guide to constructing the Pneumatic Test Stand from the projects section of the GEARS Educational Systems website ([www.gearseds.com](http://www.gearseds.com)) This module can be assembled in 1-2 hours by a team of 2-3 people. Each team member can build 1 or more of the subassemblies from which the Pneumatic Test Stand is constructed. Allow additional time for testing and debugging.

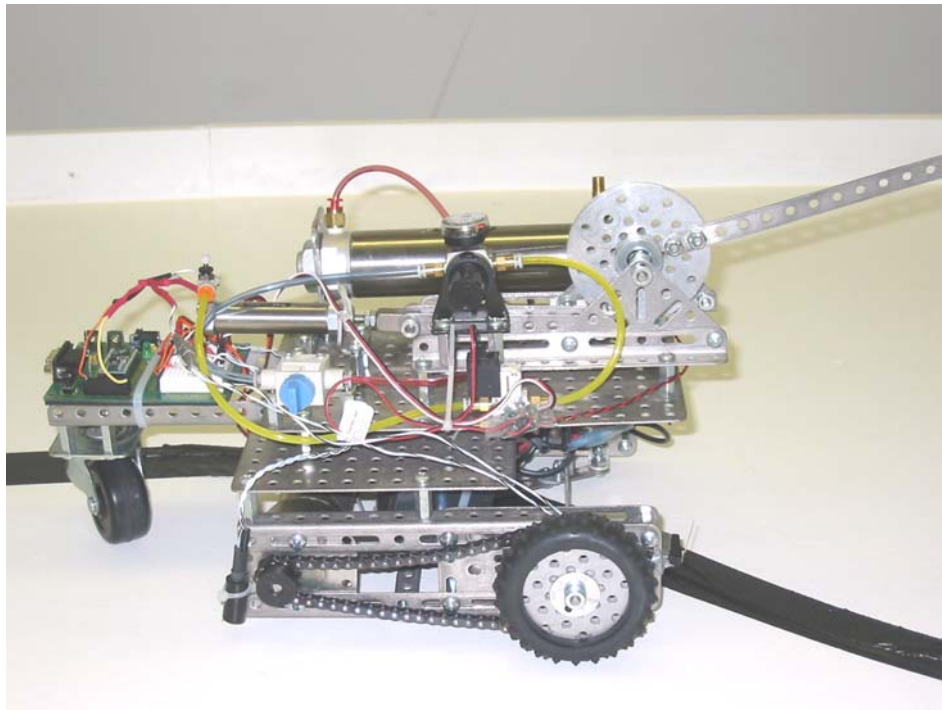

**3.) Integrate the Mobile Chassis and Pneumatic Test Stand Modules.** This is easily accomplished by mounting the pneumatic test stand module onto the mobile chassis module using eight 10-24 x 3/8" machine screws and 4 #10-24 standoffs as illustrated on the left.

**3.) Configure an RC Control System.** This illustrated project manual can be downloaded from the **GEARS** Educational Systems website

([www.gearseds.com](http://www.gearseds.com)) This module can be assembled in 1-2 hours by a team of 2-3 people. Allow additional time for testing and debugging. After assembling and testing the control system outside of the robot, integrate the components into a fully working assembly. Be certain your robot is fully functional under RC control before attempting to convert the robot to autonomous control.

Note: Engineering even the simplest mechanisms requires patience, testing and troubleshooting. This is called debugging. Be certain that your robot is operating successfully under RC control, and that you have a working understanding of the function and correct operation of the components used in these assemblies before you attempt to convert the robot to autonomous control.

**Performance Tip.** Engineering is a team sport. Be an engineering MVP. Accept and commit to completing specific responsibilities.

1. Obtain and organize the Tools and Materials (*Listed below*)
2. Build one or more of the subassemblies (*Illustrated in this and other document*)
3. Configure an RC Control System
4. Integrate the subassemblies into a working mobile catapult.

**Performance Tip.** Always collect, organize and carefully prepare all the necessary Materials, Tools and Equipment before beginning a project.

**Performance Tip.** Before beginning any project, it helps to have a sense of what the beginning, middle and end of the project looks like. For **Best Results Read the Entire Document Before Beginning**

## Tools and Materials

The construction of the Autonomous Game Playing Robot can be completed with a minimum of frustration and mistakes by taking the time to read through the directions and readying the necessary tools and materials before beginning the assembly.

**Performance Tip.** Organize the materials; Obtain boxes or plastic container measuring at least 6x9". Use these containers to store the necessary mechanical and electronic components throughout the building and testing cycle. Store the completed robot assembly on a shelf.

### Tools

Safety Glasses	Hack Saw ( <i>For Cutting Axles</i> )
#2 Phillips Head Screwdrivers	5/64, 6/32 Allen Wrenches or Hex Keys
5/16" Combination Wrench ( <i>For the Stand Offs</i> )	Dial Calipers and Tape Measures
3/8" Combination Wrench	Wire Strippers
6" Needle Nose Pliers	File
Tubing Shears or Sharp Shop Scissors	Soldering Iron
Wood Cutting Board	
Bench Vise	

### Materials

#### Parallax Components

1 BS2 BASIC Stamp™ "What's a Micro Controller" kit  
1 BASIC Stamp™ Board of Education  
1 BASIC Stamp™ Power Supply (Optional)

#### Additional Hardware

1pc. 6" long x 3/8" I.D. Rubber or plastic Tubing (Black)  
Heat Shrink  
Electrical tape

#### Additional Electronic Components

2 Photo Resistors Radio Shack Cat# 276-1657  
8' #22 gauge solid conductor wire  
2 Lever Switch Radio Shack 275-016  
2 10K Ohm resistors  
2 0-10K Ohm potentiometers

#### Electrical

2 **GEARS-IDS™** Speed Controllers  
1 **GEARS-IDS™** Valve controller  
3 2" Gear Head Motors GRDS-MC-10001  
1 SPST Toggle Switch  
1 12 volt x 1.2 Amp. Hr. SLA battery  
2' Red 18 AWG stranded wire  
2' Black 18 AWG stranded wire  
1 Roll electrical (rosin core) solder  
2-3" 1/16" heat shrink  
asstd. Wire Nuts or Solderless Connectors

#### Game Board Materials

1 4' x 8' sheet of 1/2" MDF or BCX plywood  
3 1" x 4" pcs of strapping lumber  
1 Roll Black Duct Tape  
Bright White House Paint  
Roller and/or brushes  
Large Waste Basket and Cardboard Backboard

# Converting the Robot to Autonomous Mode

## Step 1

### Learning to Use the Basic Stamp Microcontroller

Become familiar with wiring and programming a Parallax BASIC Stamp™ micro controller by following the steps below.

- 1.1 Obtain a BASIC Stamp, BS2 micro controller, a Board of Education prototyping board, a nine volt battery or suitable power supply and assortment of electronic components including hook up wires, LED's , 1K and 10k resistors, 10K potentiometers, Cds Photo resistors and a hobby servo. Hobby servos are used in Radio Controlled planes, cars and boats. The necessary components are shown below.
- 1.2 Download or purchase the Parallax document entitled; "What's a Microcontroller?"
- 1.3 Learn to write and download simple programs that will flash LED's and control the motions of hobby servos using the BASIC Stamp and a photo resistor.

Once you are able to confidently flash LED's and control the motion of servos, you will know enough to wire and program your autonomous robot.



. What's a Microcontroller? is the best introductory BASIC Stamp tutorial for teachers and students who want to build autonomous robots and automated mechanisms using the GEARS Invention and Design System and Parallax Inc, BASIC Stamp microcontrollers.

Download and review the What's a microcontroller text at this address:  
[http://www.parallax.com/dl/docs/books/edu/wa\\_mv2\\_1.pdf](http://www.parallax.com/dl/docs/books/edu/wa_mv2_1.pdf)

Purchase the right Parallax educational tools from GEARS Educational Systems.

The **Board of Education Starter Kit** is the ideal prototyping platform for wiring the circuits and sensors used in autonomous robots and automated mechanisms.

The instructions in this document illustrate how to wire the circuits and sensors used in the GEARS-IDS Autonomous Game Playing Robot. This project is constructed using **the Board of Education Starter Kit** shown on the right.

This and other Parallax products can be purchased from GEARS Educational Systems.

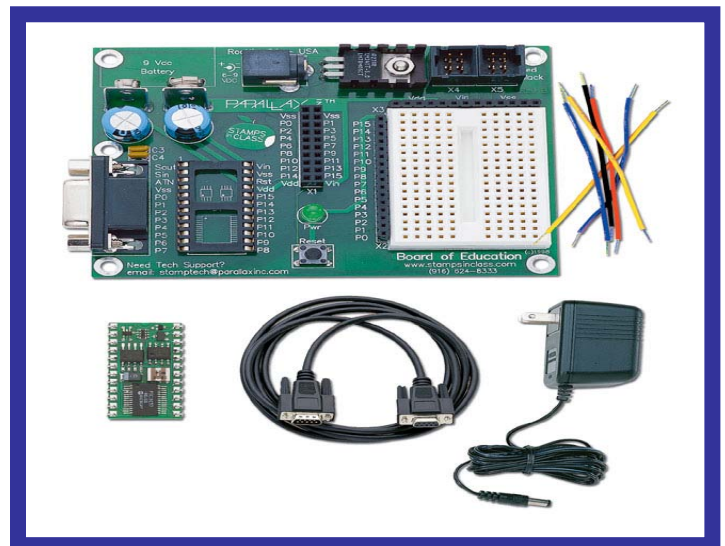

## Step 2

### Building the Photo Sensors

(2 Required)

The photo sensors are used to detect light and dark areas on the surface of a robot playing field. In this way a robot can “See” a line by detecting variances in the amount of light reflected from a surface. Note: Leave approximately 12” of wire on each of the two leads. The excess wire can be cut later.

#### Materials required:

2 Photo Resistors Radio Shack Cat# 276-1657

8’ #22 gauge solid conductor wire

1pc. 6” long x 3/8” I.D. Rubber or plastic Tubing (Black)

1/16” Heat Shrink

Rosin core Solder

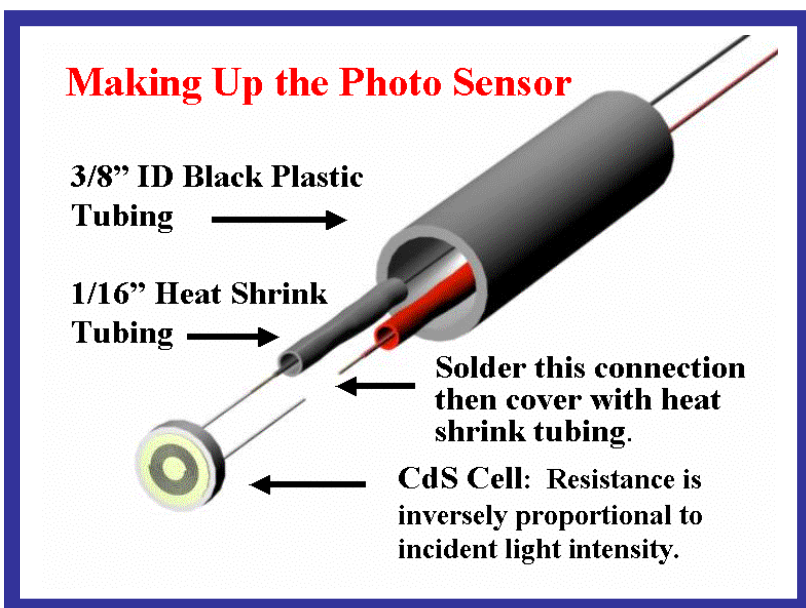

The photo sensors are made with Cadmium Sulfide photo resistors. The resistance of this material decreases when the intensity of the light shining on the surface increases.

These sensors can be easily interfaced with a BASIC stamp micro controller and the wiring and programming for this procedure is clearly explained in the “What’s a Microcontroller ?” available on the Parallax website at

[http://www.parallax.com/dl/docs/books/edu/wamv2\\_1.pdf](http://www.parallax.com/dl/docs/books/edu/wamv2_1.pdf)

Refer to pages 185 – 211 Chapter 7 for a full description.

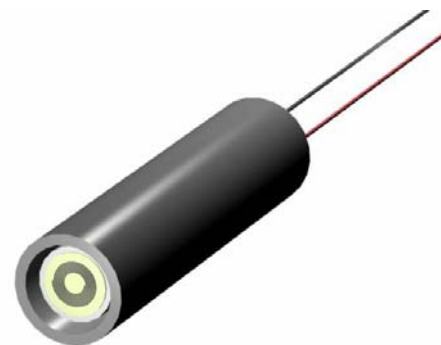
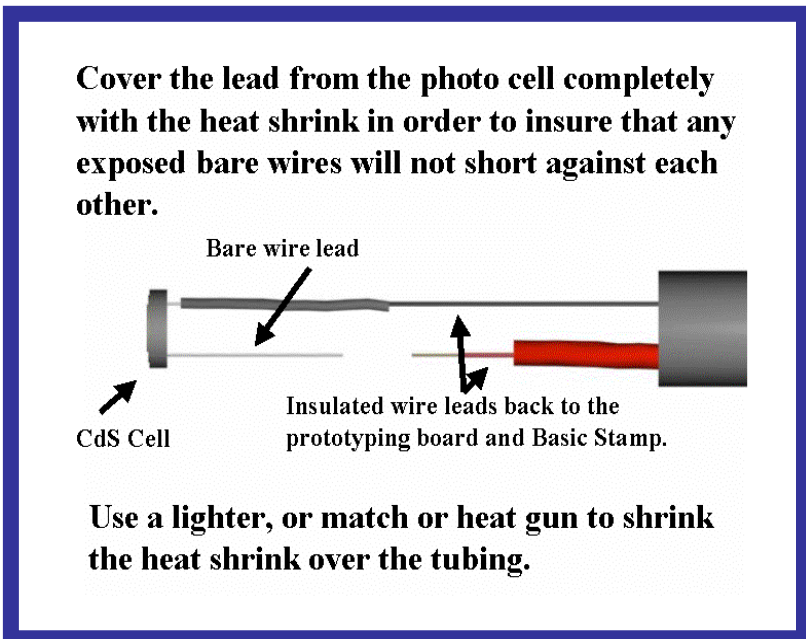

Insert the CdS cell into the plastic tubing. You will need to experiment with the setback distance. The set back ensures that the photo resistor will only “See” reflected light from the surface below it.

# Step 3

## Wiring the Circuit and Sensors

Study the diagram below in order to properly wire the photoelectric sensors, speed controllers and valve controllers. This circuit was designed and built by high school sophomore Robert Block.

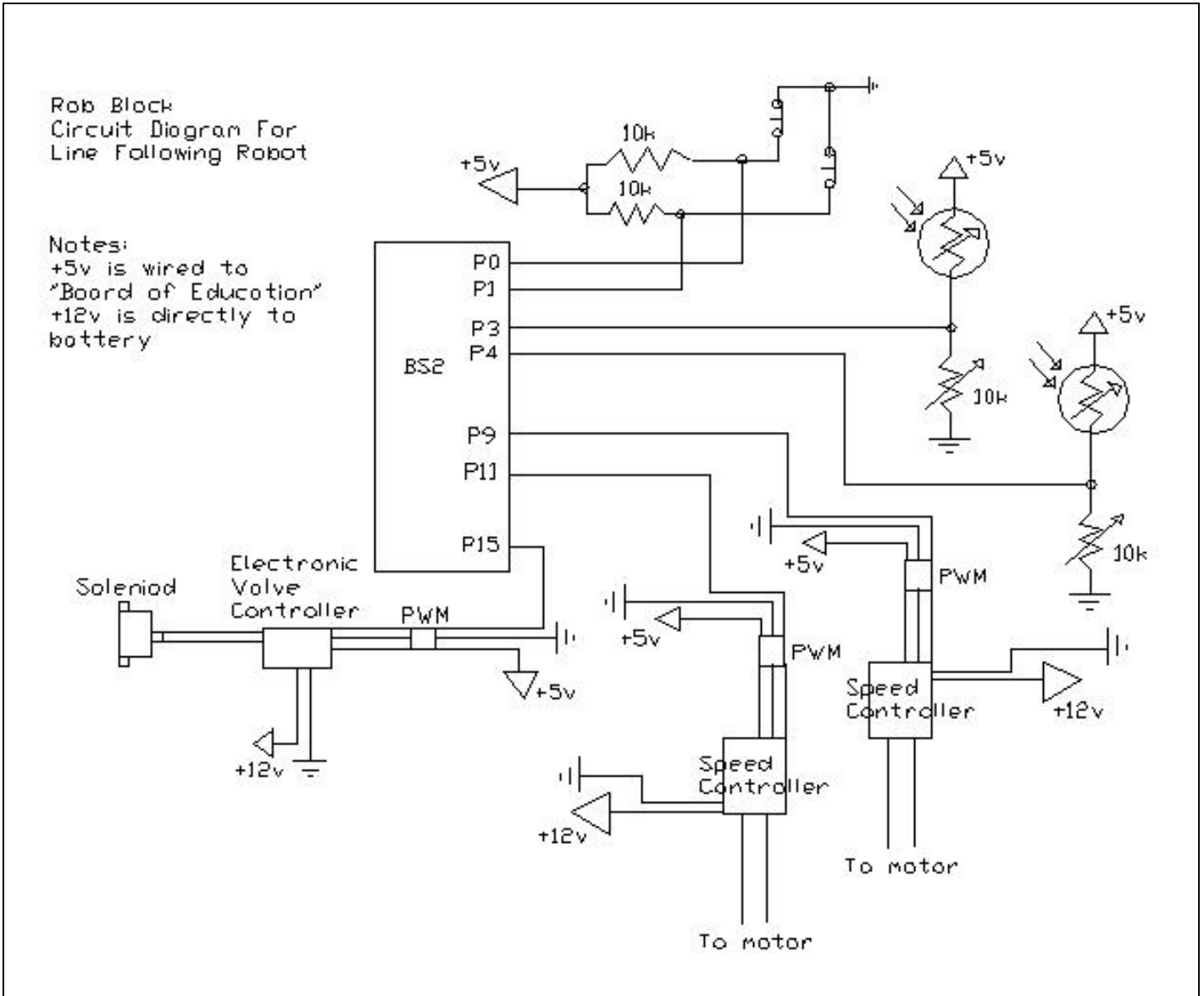

## Wiring the Speed Controller

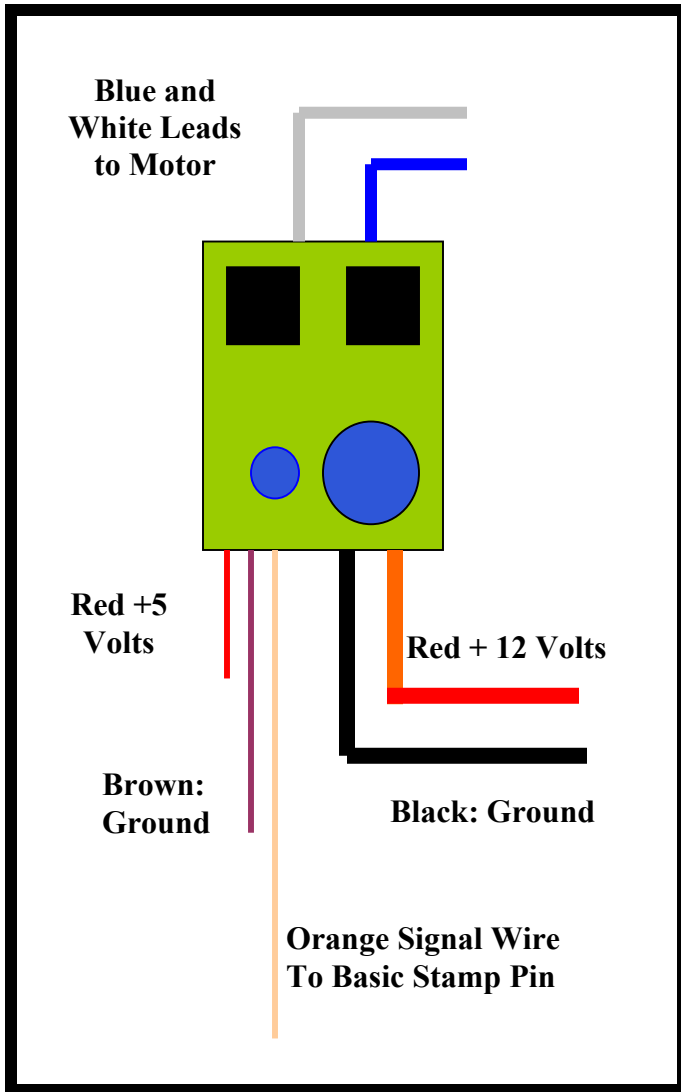

The GEARs-IDS electronic speed controllers make use of BEC (Battery Eliminator Circuitry) The PWM cables have three parallel wires. These wires are red, black and white or in some cases; brown, red and orange. In all cases the lightest colored wire (white or orange) is the signal wire. The signal wire is connected to the input pin of the BASIC Stamp. The red wire is connected to the positive +5 volts terminal on the Stamp prototyping board (Vdd) and the brown or black wire is connected to the ground (Vss).

**An easy way to connect the speed controller PWM cables to the prototyping board is through single row header pins. These are available through a variety of electronic suppliers.**

(Note photo on following page.)

**GEARs-IDS Speed Controller Wiring Diagram**

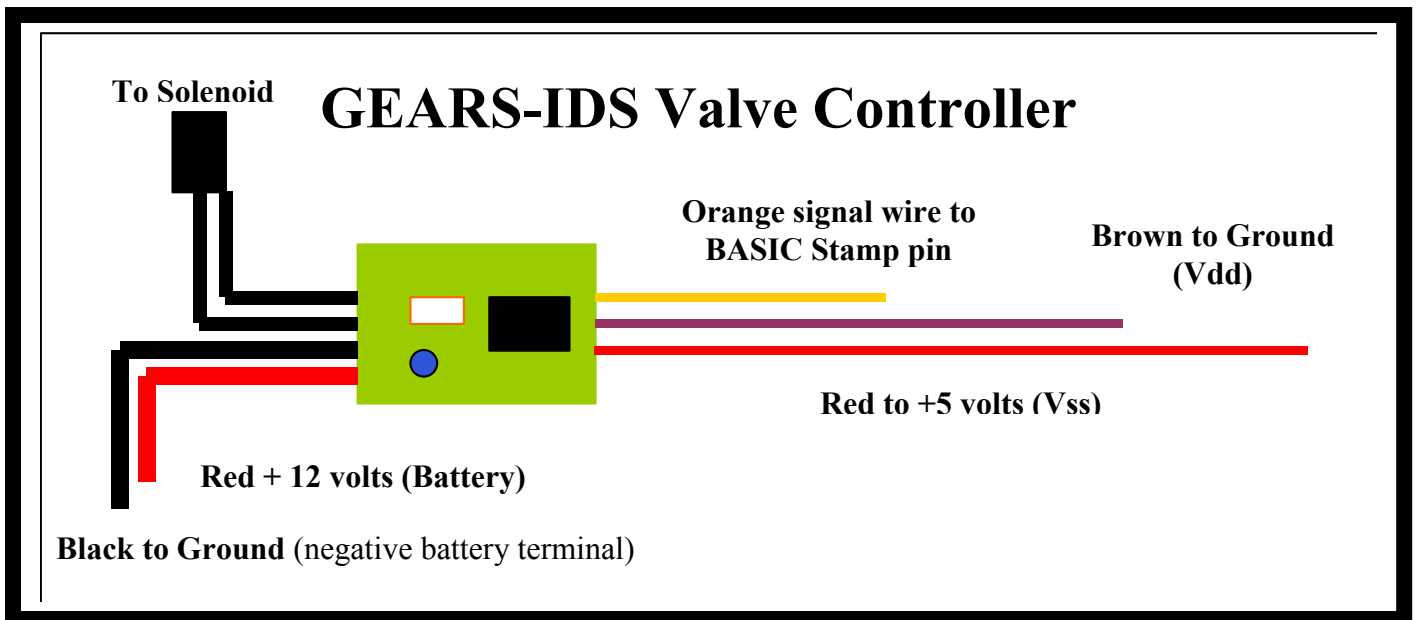

# Notes on Electronic Components

The resistors, photo-electric sensors, lever switches and potentiometers are NON Polarized components. This means you do not have to be concerned about wiring them with the wrong polarity. Either of the two leads from each component can be wired to the positive or negative side of the circuit.

## Single Row Header Pins with 0.1” Centers

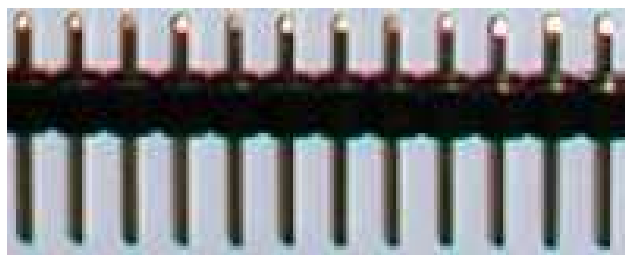
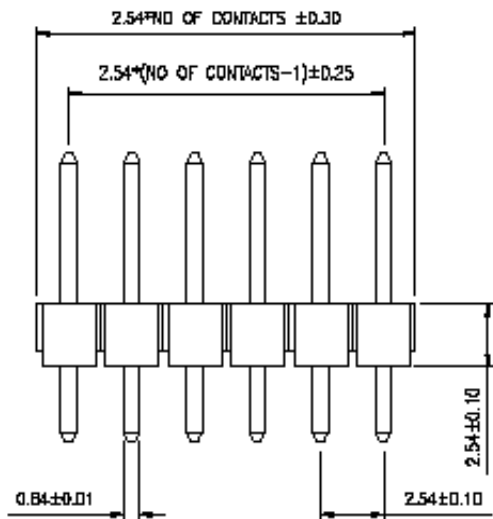

Single Row Header Pins provide convenient connection points for the standard PWM cable connectors on the GEARS-IDS speed controllers and valve controllers, as well as those same connectors found on hobby servos.

## Single Row Header Pins

Image from [floridacircuits.com](http://floridacircuits.com)

These single row header pins can be purchased from a variety of online resources including:

[www.floridacircuit.com](http://www.floridacircuit.com) and [www.allelectronics.com](http://www.allelectronics.com)

Pins can be snapped apart to make 3 pin modules.



## Rotary Linear Potentiometer



## Trimmer Potentiometers

## Potentiometers

Pots come in many shapes and sizes, several of which are pictured on the left. These components range in price from a few cents to several dollars apiece. The pictures on the left were provided by <http://www.futurlec.com> an online supplier of electronic components and kits.

Potentiometers can be wired as variable resistors by using the center tap and either one of the outside legs. (see illustration below).

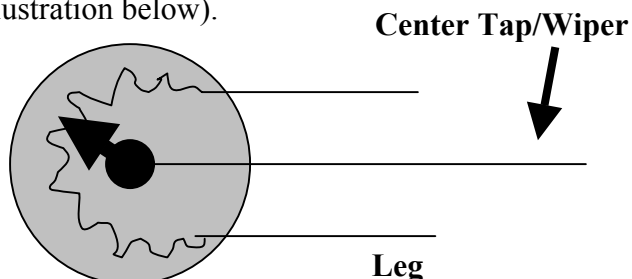

## Lever Switches or Limit Switches



Lever Switches, also called limit switches make convenient digital sensors. When the lever is depressed, a circuit can be opened or closed. Microcontrollers can be easily programmed to detect the state of the switch, and to initiate a sequence of events based on the state of the switch.



One simple application of a limit switch is to act as a “Bump” sensor, detecting when a part or side of a robot is in contact with an object or a wall.

This is how we will employ the limit switch in this project.

Note: Limit switches have three taps. Only two taps are necessary to configure the switch for a normally open or normally closed condition. In this project the switch will be configured as normally open. Normally open means the circuit is not complete and the switch is not passing current.

These switch images are courtesy of ALL ELECTRONICS Corp. These switches can be purchased online at <http://www.allelectronics.com> Keyword search “Lever Switch”.

## Mounting the Limit Switches

The Limit Switches are mounted firmly to the aluminum angle cross piece. The aluminum angle cross piece serves several functions in the design of this robot chassis. It adds structural rigidity by forming a “box” with respect to the left and right wheel bearing plates and the 6x9” top plate of the chassis. It serves to protect the axles and battery compartment and it makes a rugged and convenient mount for the limit switches.

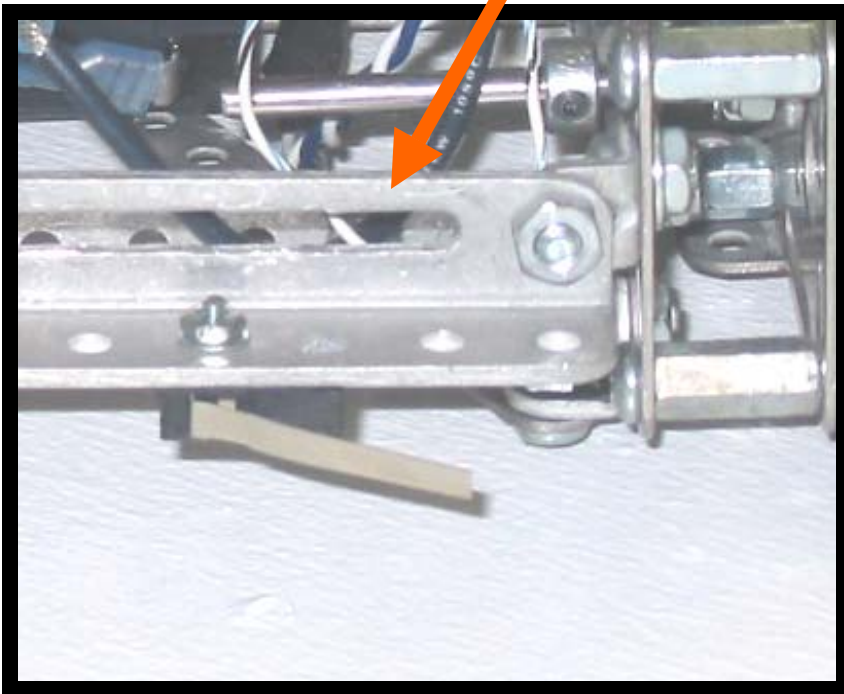
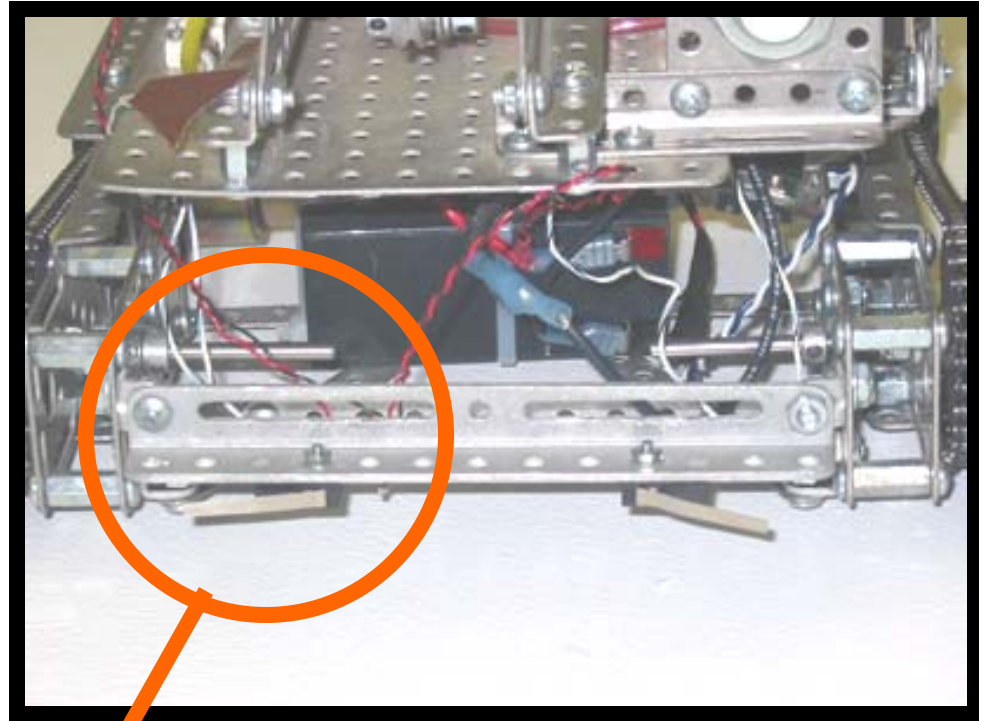

Mount the limit switches with appropriate hardware. Do not attempt to widen the switch mounting holes with a drill. Use the appropriate sized machine screw with flat washers on both sides of the limit switch. Over tightening the screws will crack the switch case and render the switch useless.

Solder or crimp on wire connectors before mounting the switch. Protect all bare conductor surfaces with heat shrink or careful taping. Heat Shrink is the preferred method.

**Use a Multimeter set to “continuity” insure that the switch operates properly BEFORE wiring it into the circuit!**

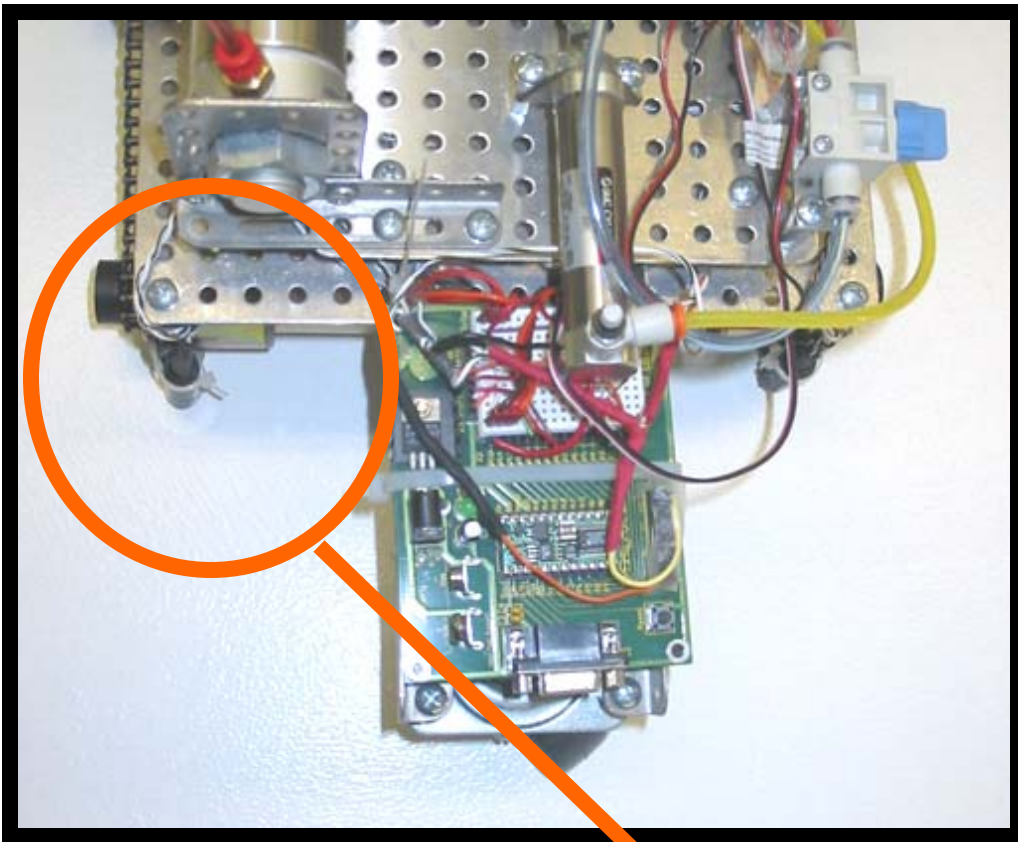

## Mounting the Photo Sensors

Mount the photo sensors to the “front” of the robot. Front is an arbitrary decision but the test robot worked well with this configuration.

Use the area above the caster wheel to mount the BASIC Stamp and prototyping board. Use a tie wrap to hold the assembly in position. Be VERY careful to insulate the bottom of the circuit board and to ENSURE that no electrical connections, solder joints or board traces come in contact with the metal frame members. This could cause a direct short and permanently damage components.

## Photo Sensor Adjustment and Following Lines

The photo sensor is wired in series with the potentiometer. (See wiring diagram on page 7) Together they form a voltage divider circuit by taking advantage of the relationship between voltage and resistance described by Ohm’s law. The simple algebra of Ohm’s law illustrates the relationship between resistance **R**, Voltage **V** and Current **I**.

$$V = I \times R$$

As light incident on the photo sensor changes, the resistance of the photo sensor changes and the voltage through the photo sensor circuit changes proportionally. When the voltage exceeds the 1.4V threshold voltage of the BASIC Stamp pin, the pin “sees” an input. It’s as though a switch had been turned on. In this way the microcontroller can query the photo sensor to determine if it is “Seeing” light or dark.

Note: You will need to experiment with slight changes in sensor height and potentiometer resistance in order to “Dial” in the sensitivity needed to distinguish light and dark areas of a line path.

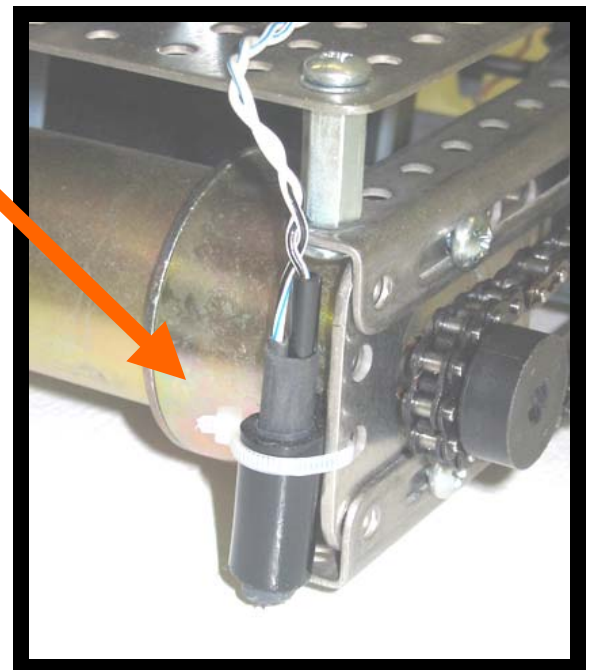

**Experiment with Sensor/floor distances and potentiometer adjustments to correctly “dial in” the correct sensitivity for line following.**

# Download and Install the BS2 Program

The GEARS-IDS Autonomous Game Playing Robot Project requires familiarity and experience with building GEARS-IDS modules, mechanisms and machines as well a working knowledge of basic electronic components and circuitry and programming the BASIC Stamp microcontroller.

Those teachers and students familiar with the BASIC Stamp products, particularly the BS2 microcontroller module will have little difficulty following these simple directions. For those students and teachers with little or no BASIC Stamp experience, we advise you to obtain a BS2 module, prototyping board and “What’s a Microcontroller?” text and take the time to become familiar with wiring and programming simple projects. This knowledge and experience will open a exciting world of engineering opportunities for the teachers and students who invest in learning to use microcontrollers.

## Programming Procedure

- 1.) If you do not already have the latest version (2.1) of the BASIC Stamp Editor, then download and install the program from the Parallax website. [www.parallax.com](http://www.parallax.com)
- 2.) From the DOCUMENT section of the GEARS Educational Systems website, download and save the [Program Code for Autonomous Game Robot](#) file on your computer. This is the BS2 program code that will operate the Autonomous Game Playing Robot.
- 3.) Open the [Program Code for Autonomous Game Robot](#) file in the BASIC Stamp editor.
- 4.) Review the code, the code comments and the wiring diagram on page 7 of this text. Take the time to identify the pins used in the code, as well as their location in the actual circuit as described by the circuit schematic on page 7. This will help you to understand how the code and circuit components are integrated.
- 5.) Attach the 9 pin serial cable from your computer to the BASIC Stamp prototyping board and download the program to the BS2 module.

Once the program download is complete, you will begin a series of trial and error experiments in which you will begin to understand the integrated operation of the machine and electronics. As your understanding grows you will become more adept at troubleshooting and refining the code and the mechanisms that are controlled by the code.

The Autonomous Game Playing Robot is a complex mechanism and it is more than likely that it will not work or work well the first time you turn it on. This is to be expected. The skill set that is most important will be developed next; this skill set is called TROUBLSHOOTING. Successful trouble shooting requires these four things:

- 1.) Patience
- 2.) Knowledge
- 3.) Organization
- 4.) Time

The following information that may help you trouble shoot the Autonomous Game Playing Robot Project.

## The GEARS-IDS Electronic Speed Controllers (ESC's)

The GEARS-IDS Electronic Speed Controllers are equipped with BEC, battery eliminator circuitry. This handy option allows the ESC to provide power for the BASIC Stamp and related 5 volt circuits. There is no need to supply the Stamp with additional power. Simply use hook up wires to connect the PWM power leads (+red and -brown or +red and- black) to the appropriate header strips Vss and Vdd on the Stamp prototyping board.

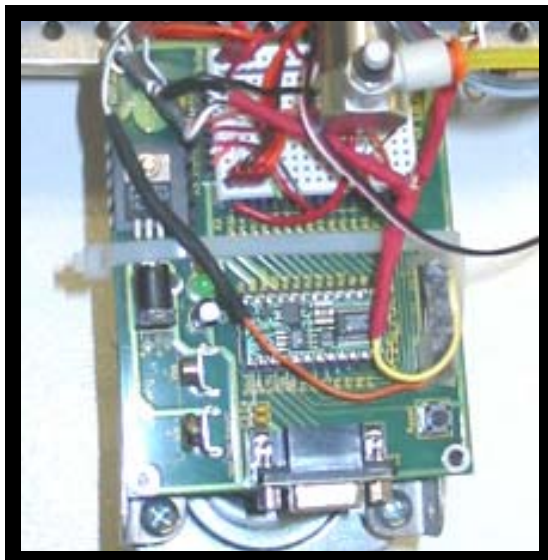
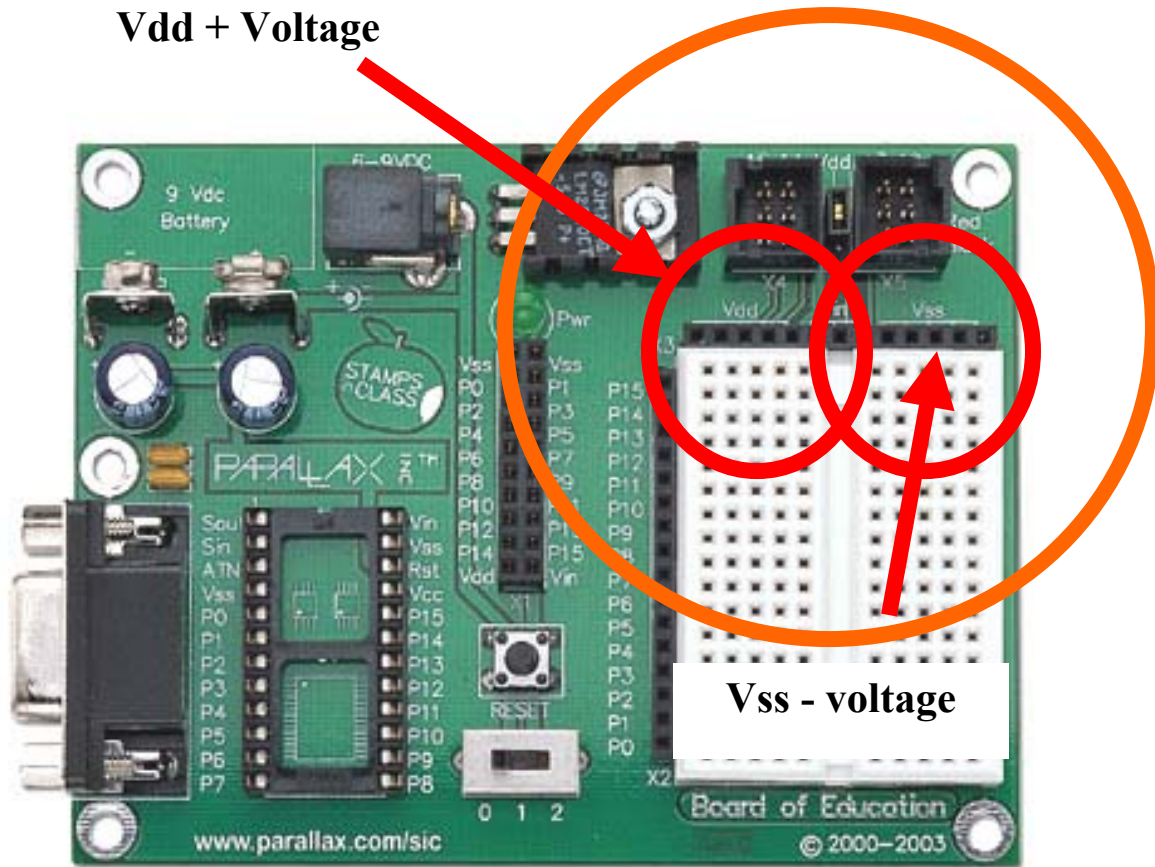

Wiring a prototype can sometimes get a little knarly. If you look closely along the left edge of the white breadboard are you can see the power leads that are plugged into the Vss and Vdd headers.

You can also see two PWM connectors that are plugged into the breadboard using a set of three pronged single row header pins. The BASIC Stamp is plugged into the 24 pin DIP socket in the center of the picture.

The GEARS-IDS Electronic Speed Controllers semi-analog control devices. It is interesting to note that the ESC's actually mimic analog control by attempting to describe a continuous functional relationship with a series of discreet "Steps". The number of discreet steps is referred to as the resolution of the controller. A Graphic example of this is illustrated below.

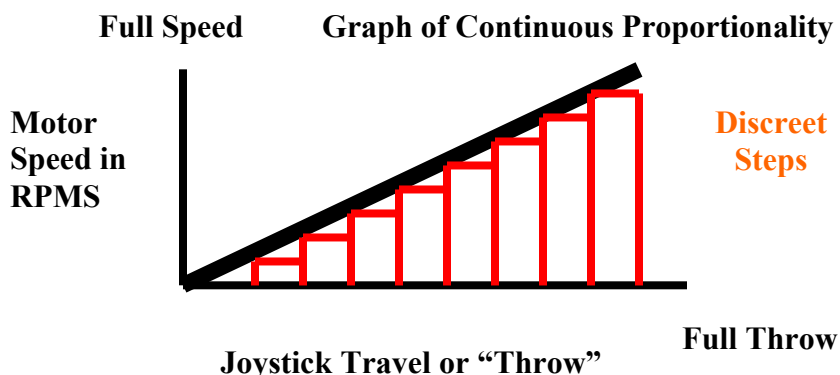

ESC's that are designed to work with RC radio controls require a steady stream of PWM signals. These PWM signals provide the instructions that determine both direction and speed. A PWM signal is divided into pulses that are between 1-2 milliseconds long. Any pulse less than 1.5 milliseconds (1-1.5ms) instructs the ESC to rotate the motor in a given direction, say CCW. Any pulse length longer than 1.5ms instructs the speed controller to rotate the motor in the reverse direction, in this case CW. The RC Radio updates the ESC every 10 –20 milliseconds, and provide it with a continuous stream of PWM signals whose values vary in proportion to the location of a joystick or thumb wheel on the radio.

The BASIC Stamp is a serial controller and it must execute a program repetitively from beginning to end. Depending on the size of the program, it may not have time to update the ESC every 10-20 milliseconds because it may be busy executing lines of code. For this reason the GEARS-IDS ESC's will hold the last PWM command received for up to 250 milliseconds. This gives the BASIC Stamp time to execute the program and update the PWM information it needs to control the ESC's.

In addition the GEARS-IDS ESC's require an initialization routine. This is a safety measure that helps to insure that a robot or mechanism controlled by a GEARS-IDS ECS will not start unexpectedly immediately after power up. Instead the microcontroller on the ESC waits until it has received a neutral signal of approximately 1.5ms. (1.45 – 1.55 millisecond pulses are sometimes required due to slight variances in the units) before it will respond to any PWM commands. This means that the ESC's must be initialized by a program that sets them to a neutral state. A typical initialization program is a FOR NEXT loop that looks like this:

```

Reinitialize:           'program label
PAUSE 950              'pause just under 1 second
FOR x=740 TO 760      'initiates a "for...next" loop that will pulsout signal widths
                       Incrementing from 740 to 760
PULSOUT Rmotor,x      'right motor receives a signal from 740 to 760, initializing the right
                       ESC
PULSOUT Lmotor,x      'left motor receives a signal from 740 to 760, initializing the left
                       ESC
PAUSE 1               'pause 1 millisecond
NEXT                  'end of "for...next" loop
RETURN

```

## The GEARS-IDS Electronic Valve Controller

The valve controller is a digital device. The valve controller can turn a current on or off as well as change the polarity of the current. Throwing the joystick forward turns the current on in one direction, while pulling the joystick back switches the current on in the opposite direction or polarity. When the joystick is in the centered position, no current will flow. This device is useful for running double throw relays and reversing small motors. When the valve controller is operated by the BASIC Stamp, it must receive PWM signals of nearly 1ms or 2 ms in order to control the polarity and energize the device. PWM signal widths of 1.7 – 750 will not be recognized by the microcontroller on the valve controller. This is done to insure that an inadvertent motion of the joystick will not activate the valve controller. Activating the valve controller requires a deliberate and full throw of the joystick in either direction.

It is also important to note that robots are electrically noisy. It is possible for motor brush arcing, armature spikes, switch arcing, and RF noise to trigger the current controlling FETS on the Valve controller. For this reason it is necessary to send the valve controller a minimum of 5 PWM commands in order to activate it. A sample code that would do this is shown below. This program also keeps the valve on for a required amount of time (about 1.5 seconds).

launch:	'program label
PAUSE 2000	'pause 2 seconds
FOR x=1 TO 205	'initiates a "for...next" loop that will repeat 205 times. The extra 5 times are to initiate the electronic valve controller
PULSOUT catapult,500	'fires the catapult
PAUSE 10	'pause 10 milliseconds
NEXT	

## Photo Sensors and Switches

The operation of the photo sensors can be checked in several ways.

A Volt Ohm Meter set to read resistance will show help determine if the photo sensor circuit is complete and functioning. In addition the use of the debug command is particularly useful for verifying the operation of the sensor. Refer to the What's a Microcontroller Text for a complete description of how to use the debug command. The same applies to the lever switches. Note, these switches can be wired as normally open (NO) or normally closed (NC). Verify that you have wired them as Normally open (NO) by using a continuity meter with audible feedback.

In order to troubleshoot complex circuits and mechanisms, it is necessary to verify the operation of each component and module that makes up the electro-mechanical system. This takes time and patience. Patience is often rewarded with understanding, knowledge and success. When something does not work, be willing to start over and "do it again". Do not make assumptions about what is or is not working, rather test and verify the operation and function of everything.

# Building the Game Table and Playing the Game

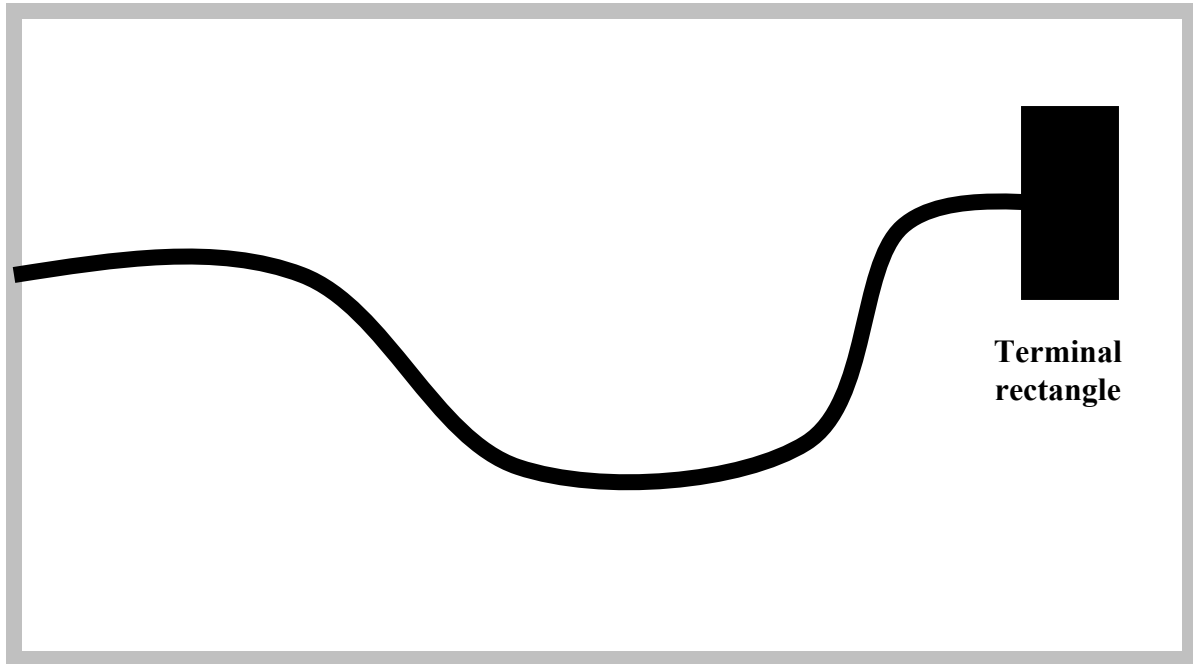

The Game table is a 4x8' sheet of Medium Density Fiberboard painted bright white. We used exterior latex paint for easy clean up and durability. Create a path using black duct tape 2" +/- wide. Create a terminal rectangle with the same duct tape. The terminal rectangle should be large enough that the robot "sees" it easily regardless of the angle it approaches at. The shape of the path is not important, but the curves should have large smooth radii or the robot can get confused.

**Waste Basket and Backboard  
placed 6-16' feet from the edge of  
the playing field.**

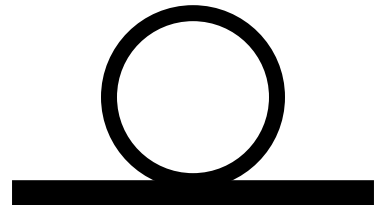

## The Game

The game objective is deceptively simple. Design and build a robot that will follow the line to the terminal rectangle. After reaching the terminal rectangle the robot will execute a turn and back up square against the retaining wall. After squaring up against the retaining wall the robot will shoot a ping pong ball into a waste basket. The throwing distance can vary between 6-16 feet or more.

The robot that successfully completes the mission in the least amount of time wins. Winning will require refining the code and optimizing the mechanics of the machine. This is a team sport requiring a variety of skills. Have fun, play safe, and **ALWAYS WEAR YOUR SAFETY GOGGLES**

Additions to the challenge might include having the robot return to the starting gate either by following the line back, or by any direct means. You could complicate things by adding a maze!